

Precision Load Cell

Model 8431

Model 8432 with overload protection

Code:	8431 EN
Delivery:	ex stock
Warranty:	24 months

CAD data 2D/3D for this sensor:
Download directly at www.traceparts.com
Info: refer to data sheet 80-CAD-EN

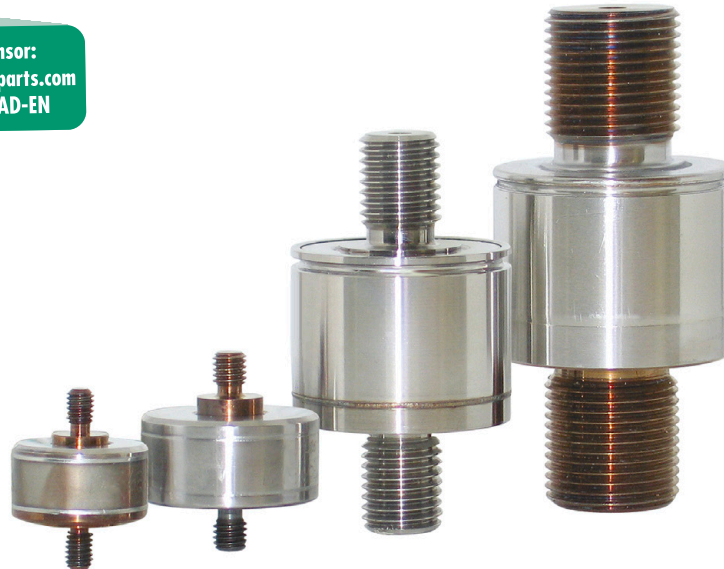

- Small dimensions
- For tension and compression forces
- Temperature compensation starting at - 55 °C and up to 200 °C optional
- Minimum lateral sensitivity due to supporting membranes
- Measurement accuracy from 0.2 % F.S.
- Measurement ranges from 0 ... 2.5 N to 0 ... 100 kN
- Model 8432 with overload protection for directions tension and compression

Application

Precise tension and compression force measurements can be performed in limited space with model 8431 and 8432 precision miniature load cells. High precision, various measuring ranges, convenient load application via threaded pins with external winding and small dimensions offer a wide scope of applications in laboratories and production.

The series are among our most precise and yet mechanically sturdy miniature load cells. All options, typical only for larger load cells, are available with this miniature series such as hermetically sealed construction, overload protection and boring for pressure compensation when applied under vacuum.

Its complex design with integrated support membranes and overload protection reduces additional construction effort for external overload protection or guidance of force of applied parts in many applications. This requires little space, has little material and weight and almost no component friction, which could falsify the measurement result.

The connection cable suitable for robot applications make the precision miniature load cells especially suitable for use in the areas of special purpose machinery manufacture, tool manufacturing and handling gear.

Description

The force to be measured is introduced via the threaded pin in the directions of both tension and compression in the cylindrically shaped sensor body. Torsion and bending forces must be avoided. It is not absolutely necessary that the interior threaded parts are seated solidly on the end of the threads or floor surface of the sensor housing. It suffices to apply the forces via the threadings, but they have to be fixed by a nut or pinch screw.

Two stabilizing membranes in the interior of the sensor reduce the lateral force and torque to a minimum and guarantee high long-term stability of the electrical and mechanical values.

The network for temperature compensation or standardization is positioned on a covered board as a thickened part of the sensor's connecting cable.

The maximum static usage force is the greatest force in the direction of the measurement axis that the sensor can endure. The overload protection is not suitable for using the sensor often in the overload range nor for sudden loads. The sensors work independent of positioning and have an active side which effects the measuring element directly, whereas the passive side is solidly connected to the housing.

Technical Data
Model 8431

Order Code	Measurement Range	Dimensions [mm]							
		A	ø B	C	ø D	F	G	H	L
8431-5005	0 ... 5 N	17.4	4.8	6.4	25.4	2.8	0.8	12.7	9.6
8431-5010	0 ... 10 N	17.4	4.8	6.4	19.0	1.3	0.4	12.7	5.9
8431-5020	0 ... 20 N	17.4	4.8	6.4	19.0	1.3	0.4	12.7	5.9
8431-5050	0 ... 50 N	17.4	4.8	6.4	19.0	1.3	0.4	12.7	5.9
8431-5100	0 ... 100 N	25.4	6.4	6.4	25.4	2.8	0.2	15.5	6.6
8431-5200	0 ... 200 N	25.4	6.4	6.4	25.4	2.8	0.2	15.5	6.6
8431-5500	0 ... 500 N	25.4	6.4	6.4	25.4	2.8	0.2	15.5	6.6
8431-6001	0 ... 1 kN	25.4	6.4	9.7	25.4	0.8	0.5	14.0	7.0
8431-6002	0 ... 2 kN	25.4	6.4	9.7	25.4	0.8	0.5	14.0	7.0
8431-6005	0 ... 5 kN	25.4	6.4	9.7	25.4	0.8	0.5	14.0	7.0
8431-6010	0 ... 10 kN	25.4	9.5	12.7	25.4	0.8	-	19.1	6.5
8431-6020	0 ... 20 kN	28.6	9.5	16.0	31.8	0.3	-	25.4	14.2
8431-6040	0 ... 40 kN	30.3	9.5	22.4	35.0	0.5	-	28.7	15.0
8431-6050	0 ... 50 kN	30.3	9.5	22.4	35.0	0.5	-	28.7	15.0
8431-6100	0 ... 100 kN	42.7	9.5	42.0	60.0	0.5	-	48.0	23.6

Model 8432 with bidirectional overload protection

Order Code	Measurement Range	Dimensions [mm]							
		A	ø B	C	ø D	F	G	H	L
8432-5002	0 ... 2.5 N	25.4	9.7	6.4	25.4	2.8	0.8	21.9	9.6
8432-5005	0 ... 5 N	25.4	9.7	6.4	25.4	2.8	0.8	21.9	9.6
8432-5010	0 ... 10 N	25.4	9.7	6.4	25.4	2.8	0.8	21.9	9.6
8432-5020	0 ... 20 N	25.4	9.7	6.4	25.4	2.8	0.8	21.9	9.6
8432-5050	0 ... 50 N	25.4	9.7	6.4	25.4	2.8	0.8	21.9	9.6
8432-5100	0 ... 100 N	25.4	6.3	6.4	25.4	2.8	0.8	21.9	9.6
8432-5200	0 ... 200 N	25.4	6.3	6.4	25.4	2.8	0.8	21.9	9.6
8432-5500	0 ... 500 N	25.4	6.3	6.4	25.4	2.8	0.8	21.9	9.6
8432-6001	0 ... 1 kN	29.4	9.5	8.0	31.8	2.6	-	23.9	10.8
8432-6002	0 ... 2 kN	32.2	9.5	9.6	38.1	0.7	-	26.7	14.5

Electrical values
Bridge resistance: (full bridge):

measuring range $\leq 0 \dots 5$ N semi conductor strain gauge
500 Ω , nominal

measuring range $\geq 0 \dots 10$ N foil strain gauge 350 Ω , nominal

Reference excitation voltage:

measuring range $\leq 0 \dots 50$ N 5 V DC or AC

measuring range $\geq 0 \dots 100$ N 10 V DC or AC

Nominal sensitivity:

measuring range $\leq 0 \dots 5$ N 15 mV/V ... 40 mV/V, nominal

measuring range $0 \dots 10$ N 1.5 mV/V, nominal

measuring range $\geq 0 \dots 20$ N 2 mV/V, nominal

Insulation resistance:

 5000 M Ω at 50 V DC

Calibration resistor:

 59 k $\Omega \pm 0.1$ %

The bridge output voltage caused by a shunt of this value is given in the calibration protocol.

Environmental conditions
Range of operating temperature:

- 55 °C ... + 120 °C

Nominal temperature range:

+ 15 °C ... + 70 °C

Influence of temperature on zero:

measuring range $\leq 0 \dots 5$ N $\leq \pm 0.05$ % F.S./K

measuring range $\geq 0 \dots 10$ N $\leq \pm 0.03$ % F.S./K

Influence of temperature on sensitivity:

measuring range $\leq 0 \dots 5$ N $\leq \pm 0.05$ % F.S./K

measuring range $\geq 0 \dots 10$ N $\leq \pm 0.03$ % F.S./K

Mechanical Value
Measurement error, consisting of relative non-linearity:

measuring range $\leq 0 \dots 1$ kN $< \pm 0.15$ % F.S.

measuring range $\geq 0 \dots 2$ kN $< \pm 0.2$ % F.S.

Relative hysteresis:

measuring range $0 \dots 5$ N < 0.3 % F.S.

measuring range $\geq 0 \dots 10$ N < 0.2 % F.S.

Kind of measurement:

Tensile and compressive forces

calibration in tensile direction (preferential direction)
expect a changed characteristic, if using the sensor against the preferential direction.

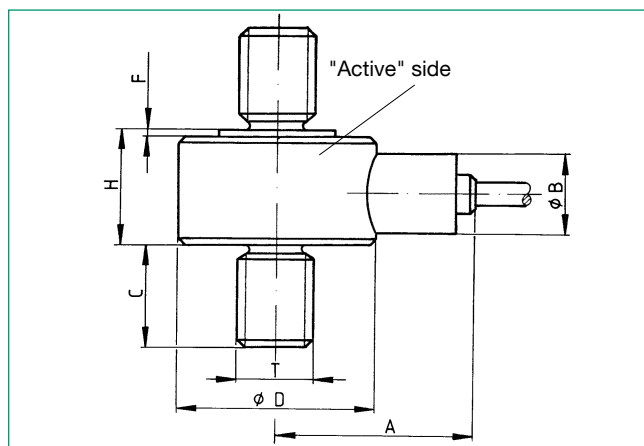
Dimensional drawing models 8431 and 8432

The CAD drawing (3D/2D) for this sensor can be imported online directly into your CAD system.

Download via www.burster.com or directly at www.traceparts.com. For further information about the burster traceparts cooperation refer to data sheet 80-CAD-EN.

Maximum static force in operation:

model 8431 all measuring range bidirectional 150 % of nominal load

model 8432 all measuring range bidirectional 100 % of nominal load

Maximum static load to overload stop:

model 8432
measuring range $\leq 0 \dots 500$ N bidirectional 500 % of nominal load
measuring range $0 \dots 1000$ N bidirectional 250 % of nominal load
measuring range $0 \dots 2000$ N bidirectional 200 % of nominal load

Dimensions: refer to table and dimensional drawing

Technical Data

Model 8431

Order Code	Measurement Range	Thread T	Resonance Frequency [kHz]	Weight [g]		Thread Adapter* Model
				with / without Cable		
8431-5005	0 ... 5 N	M 4 x 0.7	0.3	25 /	18	8431-ZX01
8431-5010	0 ... 10 N	M 4 x 0.7	0.3	25 /	18	8431-ZX01
8431-5020	0 ... 20 N	M 4 x 0.7	0.7	25 /	18	8431-ZX01
8431-5050	0 ... 50 N	M 4 x 0.7	0.9	25 /	18	8431-ZX01
8431-5100	0 ... 100 N	M 5 x 0.8	1.2	65 /	34	8431-ZX02
8431-5200	0 ... 200 N	M 5 x 0.8	2.7	65 /	34	8431-ZX02
8431-5500	0 ... 500 N	M 5 x 0.8	3.3	65 /	34	8431-ZX02
8431-6001	0 ... 1000 N	M 6 x 1.0	5.3	68 /	40	-
8431-6002	0 ... 2000 N	M 6 x 1.0	7.5	68 /	40	-
8431-6005	0 ... 5000 N	M 6 x 1.0	9.7	68 /	40	-
8431-6010	0 ... 10 kN	M10 x 1.5	1.3	88 /	60	-
8431-6020	0 ... 20 kN	M12 x 1.5	1.0	144 /	124	-
8431-6040	0 ... 40 kN	M20 x 1.5	1.0	264 /	238	-
8431-6050	0 ... 50 kN	M20 x 1.5	1.0	264 /	238	-
8431-6100	0 ... 100 kN	M30 x 2.0	0.5	1150 /	1124	-

Model 8432 with bidirectional overload protection

Order Code	Measurement Range	Thread T	Resonance Frequency [kHz]	Weight [g]		Thread Adapter* Model
				with / without Cable		
8432-5002	0 ... 2.5 N	M4 x 0.7	0.2	92 /	68	8432-ZX01
8432-5005	0 ... 5 N	M4 x 0.7	0.2	92 /	68	8432-ZX01
8432-5010	0 ... 10 N	M4 x 0.7	0.2	92 /	68	8432-ZX01
8432-5020	0 ... 20 N	M4 x 0.7	0.35	92 /	68	8432-ZX01
8432-5050	0 ... 50 N	M4 x 0.7	0.6	92 /	68	8432-ZX01
8432-5100	0 ... 100 N	M5 x 0.8	1.2	92 /	68	8432-ZX02
8432-5200	0 ... 200 N	M5 x 0.8	2.7	92 /	68	8432-ZX02
8432-5500	0 ... 500 N	M5 x 0.8	3.3	92 /	68	8432-ZX02
8432-6001	0 ... 1000 N	M6 x 1.0	3.4	142 /	125	8432-ZX03
8432-6002	0 ... 2000 N	M6 x 1.0	3.8	238 /	210	8432-ZX04

* By ordering studs as spare parts, state serial number of the load cell.

Dynamic load:

recommended 70 % of nominal load
possible 100 % of nominal load

Deflection: 15 µm ... 50 µm

Material: stainless steel 17-4 PH (similar to 1.4542)

Electrical connection:

Shielded, high flexible, Teflon isolated cable, length approx. 1.5 m, diameter 2.0 mm. The cable has a 50 mm bend protection at the sensor body, outer diameter 3.6 mm. The minimum bending radius of the cable is 30 mm, or 8 mm at static operations.

Only model 8431, measuring range $\geq 0 \dots 100$ kN

High flexible, Teflon isolated strands, length approx. 1.5 m, overall diameter 2.5 mm; minimum bending radius of the cable 20 mm, or 5 mm for static operations. There is no bend protection available. Cable port with PG screwing mini M8.

Protection class: acc. to EN 60529 IP65

Wiring code:

red	excitation voltage	positive
black	excitation voltage	negative
green	output signal	negative
white	output signal	positive

Dimensions: refer to table and dimensional drawing

Wiring for submarine cable:

red	excitation voltage	positive
brown	excitation voltage	negative
yellow	output signal	negative
orange	output signal	positive

Dimensions: refer to table and dimensional drawing

Weight: see table

General tolerance of dimensioning: acc. to ISO 2768-f

Order Information

Precision miniature load cell, measurement range 0 ... 2000 N
state options additionally **8431-6002**

Options

Extension of the nominal temperature range
to -30 °C ... 95 °C for measuring ranges $\geq 0 \dots 100$ N ...-VxExxxxx

Extension of the nominal temperature range
to 20 °C ... 120 °C for all measuring ranges available ...-VxFxxxx

Extension of the nominal temperature range
to 20 °C ... 160 °C for measuring ranges $\geq 0 \dots 100$ N ...-VxGxxxx

Extension of the nominal temperature range
to 20 °C ... 200 °C, for measuring ranges $\geq 0 \dots 100$ N ...-VxHxxxx

Extension of the nominal temperature range
to -55 °C ... 120 °C for measuring ranges $\geq 0 \dots 20$ N ...-Vxlxxxx

Submarine cable, up to 80 °C, pressure proof up to 35 bar,
length of cable 3 m, diameter of cable 7.3 mm, bending radius 60 mm
Please inform us, if you wish another cable length.

Although the dimensions A and \varnothing B - see drawing -
are changing to A = 90 mm, \varnothing B = 12.7 mm. ...-Vxxxlxxx

Note: All options, stated above, are only available for load cells of
measurement ranges $\leq 0 \dots 40$ 000 N.

Standardization of the characteristic in the sensors connection cable to
1.5 mV/V \pm 0.25 %. Therefore a small circuit board (L 30 mm x W 8 mm)
with resistors is attached to the cable, approx. 30 cm away from the
cable's end.

Available for measurement ranges $\geq 0 \dots 10$ N ...-V015

Longer Cable

In general, with regard to the delivery time, it is possible to attach a
longer cable to each sensor. If the sensor is available ex stock it is
possible to extend the cable by a circuit board. This will result in a
shorter delivery time as for a new cable.

Permissible External Forces

Due to this precision miniature load cells construction with two stabilizing support membranes, it is only slightly sensitive to non-central forces applied to the sensor.

The influence of these undesired external forces cannot be globally quantified with certainty. It depends on the sensor's measuring range and from which side the force is applied. As a rule of thumb, the amount of external force influence on the measurement signal is between 0.25 % and 1 % depending on the measurement range as long as it is within the range of the table below.

The table shows the maximum percentage values that the external forces can have in relation to the respective measurement range of the load cell. The total of all loads on the load cell (forces and torques) should not exceed 100% of the measurement range.

The torque entries refer to a gap of 25 mm from the point of force application to the sensor surface or the sensor axis.

End Value of Meas. Range up to	Shear Force (Lateral Force) [% F.S.]	Bending Torque (Bending Force) [% F.S.]	Torsion (Torque) [% F.S.]
0 ... 2 kN	50	40	25
0 ... 10 kN	30	25	25
0 ... 100 kN	20	20	10

Accessories

Connectors

12 pin suitable to all burster desktop units

Model 9941

9 pin, suitable to SENSORMASTER and DIGIFORCE® model 9310

Model 9900-V209

Mounting of a connector to the sensors connection cable for main usage in preferential direction (positive signal for tensile load)

Order code: 99004

only for connection of the sensor to SENSORMASTER model 9163 desktop unit

Order Code: 99002

against the preferential direction (positive signal for compressive load)

Order Code: 99007

only for connection of the sensor to SENSORMASTER model 9163 desktop unit

Order Code: 99008

Sensor electronics, amplifier and process control units like modular amplifier model 9243, digital indicator model 9180 or DIGIFORCE® model 9307 **refer to section 9 of the catalog.**

Spare part threaded bolt

The threaded bolts attached to the sensor are also available as a substitution part. The bolt suitable to the particular sensor is given in the table.

Adapter

If a sensor of the model 8431 or 8432 should be mounted on a plunger of a press, a centering and mounting adapter with a 10 H7 mounting hole is available.

Centering and mounting adapter with internal thread M 4 x 0.7

5501-Z014

Centering and mounting adapter with internal thread M 5 x 0.8

5501-Z015

Factory Calibration Certificate (WKS)

Calibration of a load cell separately as well as connected to an indicator. Standard is a certificate with 11 points, starting at zero, running up and down in 20% increments covering the complete measuring range for preferential direction. Special calibrations on request. Calculation of costs by base price plus additional costs per point.

Order Code 84WKS-84...