

# Precision Torque Sensor

## Non-contact transmission for rotating applications optional measurement of angle and speed

Code: 8661 EN  
 Delivery: 1 - 2 weeks  
 Warranty: 24 months

### Model 8661

CAD data 2D/3D for this sensor:  
 Download directly at [www.traceparts.com](http://www.traceparts.com)  
 Info: refer to data sheet 80-CAD-EN



#### New Features

**Optional  
 USB interface  
 and dual range**

- Measuring range from 0 ... ± 0.05 Nm to 0 ... ± 200 Nm
- High linearity of ≤ ± 0.05 % F.S.
- Intelligent operating state indicator
- 16 bit D/A converter including digital adjustment
- Output signal 0 ... ±10 V
- Angle measurement accuracy to 0.09° (option)
- Mechanical power computation (option USB) with powerful software DigiVision
- Excellent price-performance ratio

#### Application

The series 8661 precision torque sensor is the ideal choice for reliable measurement of static and dynamic clockwise and counter-clockwise torques.

Thanks to the non-contact transmission of the excitation voltage and measurement signal, the sensor offers virtually maintenance-free and fail-safe operation. This makes it perfect for industrial production and assembly applications where there is a need to measure actuating or breakaway torques, holding torques or tightening torques.

Its high measurement quality means that the sensor is equally suited to quality control applications and laboratory-based research and development projects.

For network-independent, mobile use, the torque sensor offers an optional USB interface. This can be connected to a notebook running the PC software supplied with the device to take on-site measurements with accompanying visualization and archival of measurement values.

The applied torque can be read easily by evaluation units or controllers connected to the normalized analog interface.

Its compact, robust and vibration-proof construction makes it suitable for use in the following example applications:

- ▶ Test setups for precision mechanics
- ▶ Measurements on micromechanical actuator elements
- ▶ Engine test benches including measurement of mechanical power
- ▶ Recording biomechanical movements in medical engineering
- ▶ Precision frictional torque measurements on bearings
- ▶ Use as test-bench measuring device

#### Description

The measuring shaft, which is made of high-quality materials, carries metal-film strain gauges. Torsion of the shaft by the torque to be measured produces a change in resistance in the full bridge, which is converted into an analog signal that is proportional to the torque.

To ensure wear-free operation, the power is supplied by inductive coupling and the measurement signals are transmitted optically.

The signal, which has been digitized already on the shaft, is converted and amplified into a 0... ±10 V signal by a 16-bit digital-to-analog converter on the stator. A high-resolution TTL output signal for the angular displacement and rotational speed measurement is achieved by optical sensing of an incremental encoder disk with up to 1024 divisions and two offset tracks plus four-edge decoding.

An extra socket in addition to the standard 12-pin connector provides another option for connecting an external supply. Continuous, online display of the various operating states is provided by a 3-LED optical indicator.

High-quality bearings, tight manufacturing tolerances and excellent balance are essential for achieving the optimum running stability that this sensor delivers at speeds of over 25 000 rpm.

Technical Data

Table 1

Order Code	A1 ±0.05	A2 ±0.05	A3 ±0.03	B	B1	D1 g <sup>6</sup>	D2 g <sup>6</sup>	D3 -0.05	D4 ±0.03 deep	H	H1	L	L1	L2	L3	L4	LK ±0.05	LK1 ±0.05	LK2 ±0.05	M1 deep	M2 deep
8661-4050-VXXXX	45	31	30	40	40	5	8	29	3.1 x 5	60	15	87	64.5	10	11	66	-	26	24	M4 x 8	M3 x 5.5
8661-4100-VXXXX	45	31	30	40	40	5	8	29	3.1 x 5	60	15	87	64.5	10	11	66	-	26	24	M4 x 8	M3 x 5.5
8661-4200-VXXXX	45	31	30	40	40	5	8	29	3.1 x 5	60	15	87	64.5	10	11	66	-	26	24	M4 x 8	M3 x 5.5
8661-4500-VXXXX	45	31	30	40	40	5	8	29	3.1 x 5	60	15	87	64.5	10	11	66	-	26	24	M4 x 8	M3 x 5.5
8661-5001-VXXXX	45	31	30	40	40	5	8	29	3.1 x 5	60	15	87	64.5	10	11	66	-	26	24	M4 x 8	M3 x 5.5
8661-5002-VXXXX	45	31	30	40	40	6	8	29	3.1 x 5	60	15	94	64.5	14	14	66	-	26	24	M4 x 8	M3 x 5.5
8661-5005-VXXXX	57	44	41	55	40	15	15	54	3.1 x 5	85	27.5	143	64.5	30	30	83	64	-	-	M5 x 9	M4 x 6
8661-5010-VXXXX	57	44	41	55	40	15	15	54	3.1 x 5	85	27.5	143	64.5	30	30	83	64	-	-	M5 x 9	M4 x 6
8661-5020-VXXXX	57	44	41	55	40	15	15	54	3.1 x 5	85	27.5	143	64.5	30	30	83	64	-	-	M5 x 9	M4 x 6
8661-5050-VXXXX	57	44	41	64	40	26	26	58.5	3.1 x 5	94	32	170	64.5	45	45	78	77	-	-	M6 x10	M4 x 6
8661-5100-VXXXX	57	44	41	64	40	26	26	58.5	3.1 x 5	94	32	170	64.5	45	45	78	77	-	-	M6 x10	M4 x 6
8661-5200-VXXXX	57	44	41	64	40	26	26	58.5	3.1 x 5	94	32	170	64.5	45	45	78	77	-	-	M6 x10	M4 x 6

Dimensional drawing

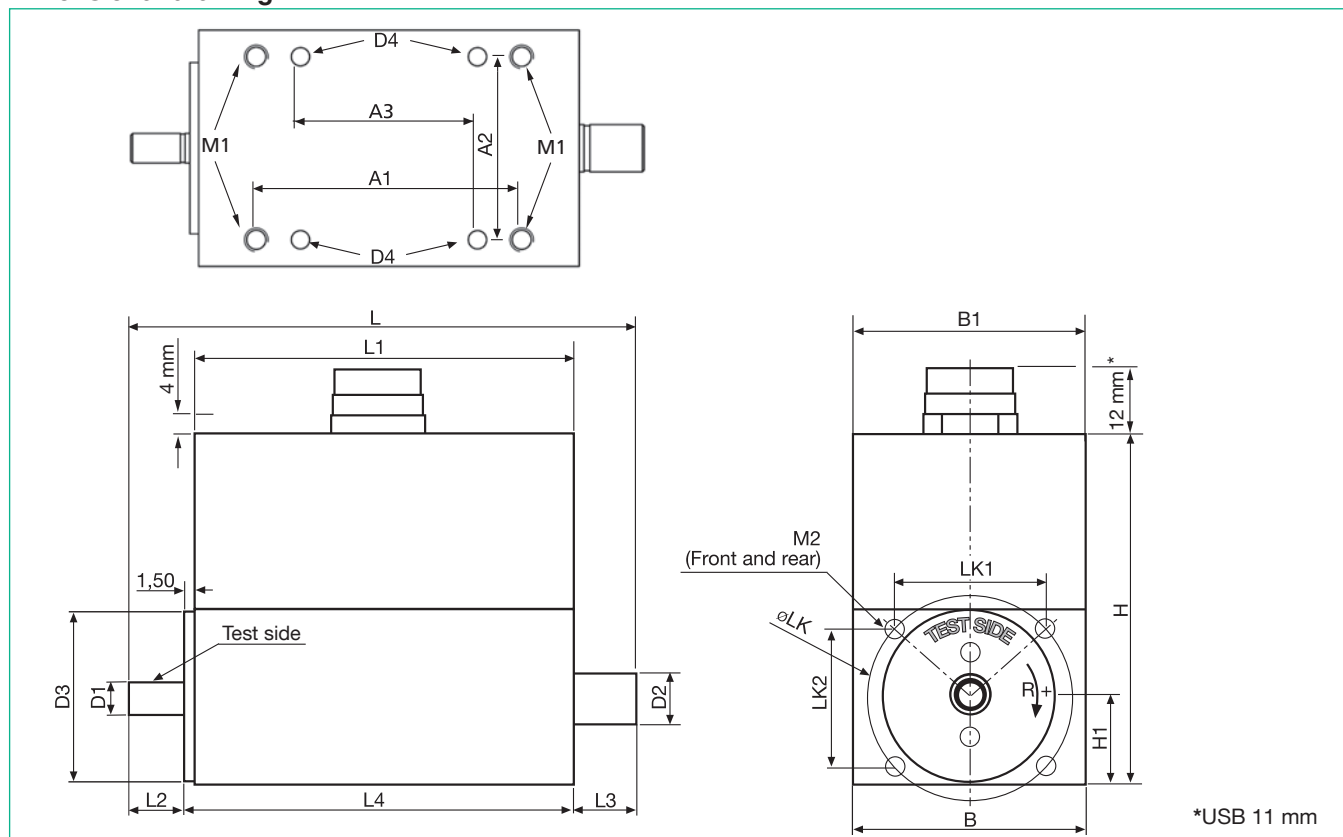

Specifications, based on measurement range Table 2

Ordercode	Measurement Range [Nm]	Spring Constant [Nm/rad]	Mass Moment of Inertia Drive Side [10 <sup>-6</sup> kg*m <sup>2</sup> ]	Mass Moment of Inertia Measuring Side [10 <sup>-6</sup> kg*m <sup>2</sup> ]	Maximum Permissible Axial Load [N]	Maximum Permissible Radial Load [N]	Weight [g]	Max. Rotary Speed** [min <sup>-1</sup> ]
8661-4050-V0XXX	0 ... ± 0.05	10	2.2	0.048	140	3	300	25 000
8661-4100-V0XXX	0 ... ± 0.1	20	2.2	0.048	140	3	300	25 000
8661-4200-V0XXX	0 ... ± 0.2	50	2.2	0.05	140	3	300	25 000
8661-4500-V0XXX	0 ... ± 0.5	100	2.2	0.06	160	4	300	25 000
8661-5001-V0XXX	0 ... ± 1	100	2.2	0.062	210	7	300	25 000
8661-5002-V0XXX	0 ... ± 2	180	2.2	0.077	210	13	300	25 000
8661-5005-V0XXX	0 ... ± 5	800	14.3	2.2	1200	15	900	15 000
8661-5010-V0XXX	0 ... ± 10	1700	14.3	2.35	1300	30	900	15 000
8661-5020-V0XXX	0 ... ± 20	3000	14.6	2.6	1300	60	900	15 000
8661-5050-V0XXX	0 ... ± 50	14000	85.7	33.30	1800	125	1500	15 000
8661-5100-V0XXX	0 ... ± 100	25000	85.9	33.70	1800	215	1500	15 000
8661-5200-V0XXX	0 ... ± 200	40000	87.5	35.00	1800	450	1500	15 000

\*\*The option angle and speed measurement restrict the measurement function (see „Technical data“, page 6)

## Torque Sensor with integrated USB Interface (option)

- Includes powerful data acquisition software DigiVision
- Plug & Measure
- Numerical and graphical display of torque/angle or torque/speed/mechanical power
- Suitable for mobile use with a notebook
- Power supply via the USB-port (External power supply is not required)
- DLL and LabView-driver for free

This sensor version has an USB-port instead of the 0 - 10 Volt output. The measurement signal is transferred digitally from the measuring shaft and then transmitted serially. This allows a PC-based evaluation of the measurement signals.

Beside torque, speed or angular displacement measurement values are provided optionally. The DigiVision software displays the mechanical power values also calculated by the sensor.



### Configuration and Evaluation Software DigiVision

Multichannel configuration and evaluation software suitable for easy PC-based analysis and reporting in mobile and stationary applications field such as lab, R & D and industrial environment.

#### DigiVision, 8661-P001 (included)

- For a single sensor only
- Max. 200 measuring values per second

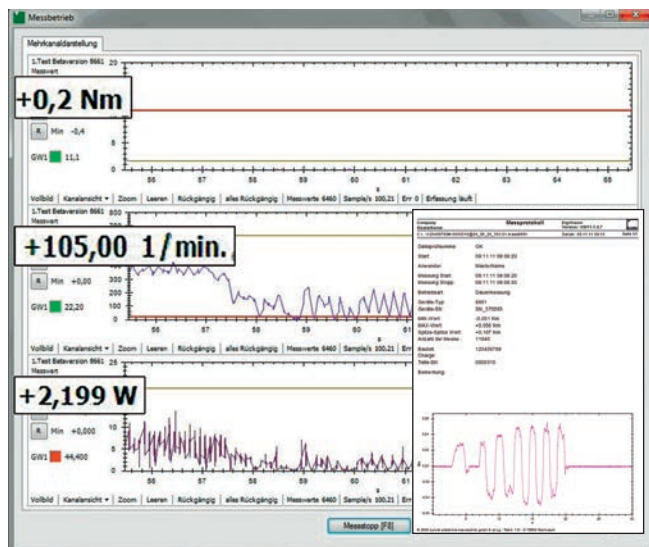

Screenshot P001: Multichannel display of a single sensor, below right: printed measuring record

#### DigiVision Features

- ▶ Numerical and chart representation of the torque, speed, angle and mechanical power
- ▶ Intuitive user interface
- ▶ Automatic sensor detection
- ▶ Several innovative start and stop trigger features
- ▶ 4 limits per channel configurable
- ▶ Peak value memory for MIN/MAX
- ▶ Auto scale
- ▶ Storage function of the measuring log as Excel or PDF file
- ▶ Archive viewer including curve array display
- ▶ Multi channel operation with full version possible (8661-P100)
- ▶ Calibration data are stored in the sensor

#### DigiVision, 8661-P100

- For more sensors, up to 16 channels
- Max. 400 measuring values per second, per channel
- Depending on the sensor version each sensor can be displayed as follows:
  - Torque and / or angle or
  - Torque / speed / mechanical power

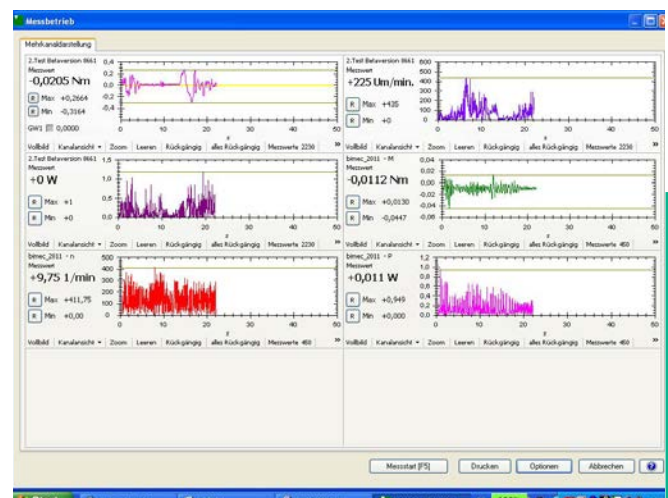

Screenshot P100: Multichannel display of two sensors, torque / speed / mechanical power

#### Signalprocessing

Measuring rate: up to 200 meas./s (with 8661-P100) for each channel  
A/D conversion 16 bit

#### Operating System requirements

Windows 2000, XP, Vista und Window 7

#### Accessories

Configuration and evaluation software DigiVision for torque / speed / mechanical power (up to 200 meas/s supply with the device) **Model 8661-P001**

Configuration and evaluation software DigiVision with option for torque / speed / mechanical power up to 400 meas/s for multi channel operation

**Model 8661-P100**

Connector USB Mini-B with PG-gland **Model 8661-Z010**  
USB-cable, 2 m length (included)

## Sensor with 2 Measurement Ranges (option)

The sensor with two measuring ranges has the same dimensions as the standard version but it also has two different calibrated measuring ranges.

The dual range sensor offers significant advantages:

1. With a single sensor a very wide range of torques can be measured accurately.
2. Good overload protection particularly in smaller measuring ranges: The sensor provides a five fold overload protection for the smaller measuring range and a 1.5 fold overload protection for the larger measuring range.
3. No retooling time at all and only one coupling pair is needed.

With the sensor with the 12 pin connector the measuring range is switched by applying a voltage level whose magnitude and whose ground reference correspond to the control signal. (For measuring range 1:1, 0 ... 3 V, for the extended measuring range 10 ... 30 V) The switching time is max. 50 ms.

Typical applications of the dual range sensor are:

- ▶ Test stands for motors, turbines and gears, extruders
- ▶ Engineering
- ▶ Drive engineering
- ▶ Aeronautics and space sector
- ▶ Automotive
- ▶ Product development
- ▶ Quality assurance

Specification, based on measurement range **Table 3**

Order Code	Upper range value [Nm]	Measuring range extension End value second range			Spring constant [Nm/rad]	Mass Mo- ment of Inertia Drive Side [10 <sup>-6</sup> kg**m <sup>2</sup> ]	Mass Moment of Inertia Measuring Side [10 <sup>-6</sup> kg**m <sup>2</sup> ]	Permis- sible Axial Load [N]	Permis- sible Radial Load [N]	Weight [g]
		1:10	1:4,	1:5						
8661-5005-VX000*	0... ± 5	± 0,5 Nm		± 1 Nm	300	14.3	2.2	1200	15	900
8661-5010-VX000*	0... ± 10	± 1 Nm		± 2 Nm	600	14.3	2.35	1300	30	900
8661-5020-VX000*	0... ± 20	± 2 Nm	± 5 Nm		1200	14.6	2.6	1300	60	900
8661-5050-VX000*	0... ± 50	± 5 Nm		± 10 Nm	7000	85.7	33.30	1800	125	1500
8661-5100-VX000*	0... ± 00	± 10 Nm		± 20 Nm	14000	87.5	33.70	1800	215	1500
8661-5200-VX000*	0... ± 200	± 20 Nm	± 50 Nm		25000	87.5	35.00	1800	450	1500

\* X = 1: range extension 1:10, X = 2: range extension 1:5, X = 3: range extension 1:4

\*\*without option angle and speed measurement

### Example application in motor testing: High dynamics, small torque, accurate measurement

#### Task

- ▶ Miniature electric motors need to be intensively tested after final assembly as standard to assess their electro-mechanical properties.
- ▶ The torque and speed need to be measured, which will be used later to assess mechanical performance parameters.
- ▶ The test setup shall provide high precision, straightforward measurement-signal processing and overload protection.

#### Solution

- ▶ The low torques in this application mean that the measurement range must be chosen to achieve the necessary accuracy and overload protection
- ▶ The sensor is mounted so that it is freely suspended between two full couplings: between sensor and drive and between sensor and transmission arm. These couplings allow correction of misalignments in height and angle and also adjustments in length.
- ▶ To protect the sensor from inadmissible outside mechanical forces in the form of bending stress, suitable support bearings are required near the sensor.
- ▶ The measurement signals for the torque (0 ... ± 10 V) and for the speed (TTL) are available to the user for further processing.
- ▶ With the optional USB interface, using the application oriented software DigiVision allows an easy evaluation. Beside capturing, visualising and archiving of measuring data, DigiVision computes the mechanical power.

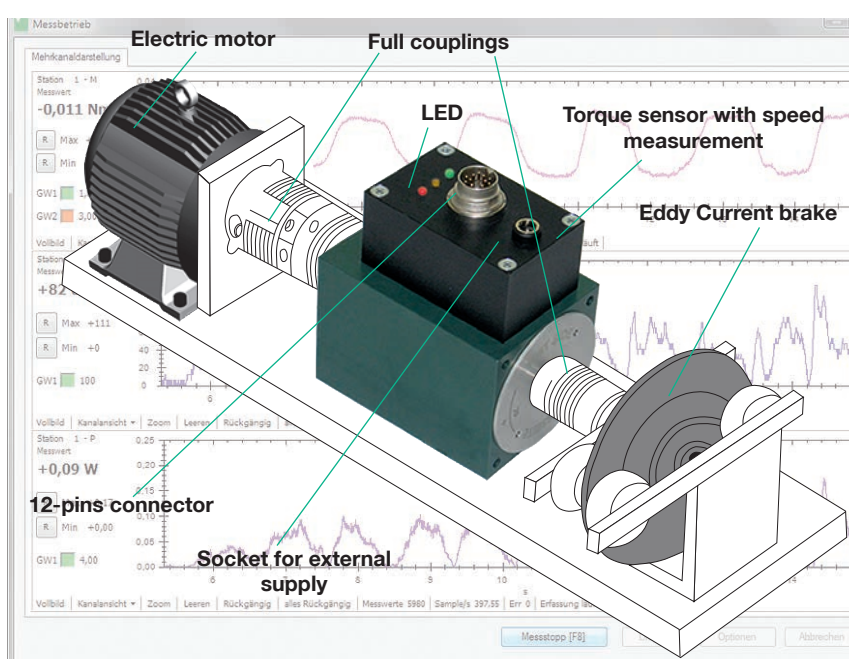

## Accessory mounting block model 8661-Z00X

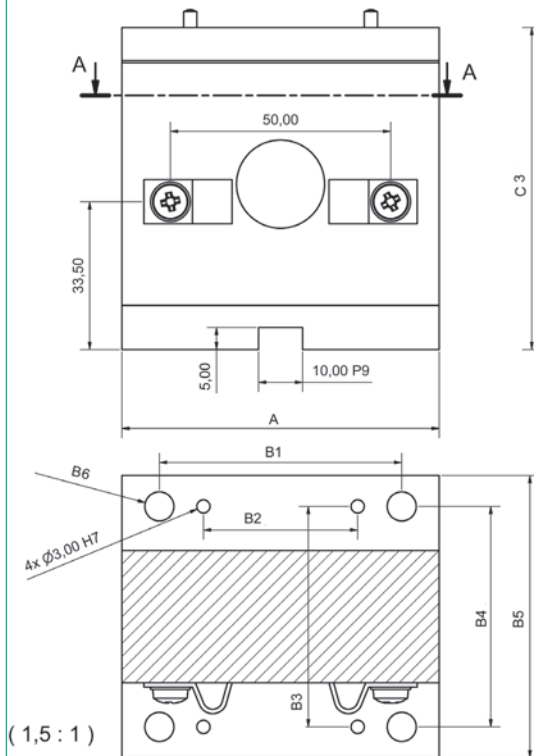

### Installation note

A fixed mount is helpful if the sensor often has to be removed and refitted. The mounting block has a central hole and special design allowing a range of options for reliable cable attachment. Two clips ensure the sensor is fixed securely.

For measuring ranges < 100 Nm (because of the load from its own weight) and at higher speeds of 10,000 rpm and above (because of resonance effects), the sensor housing should be mounted on the existing mechanical structure.

A mounting block is provided for this purpose.

Measuring Range	A	B1	B2	B3	B4	B5	B6	C1	C2	C3	C4
0.05; 0.1; 0.2; 0.5; 1; 2 Nm	64.5	50	35	30	30	40	4x5.50	20	40	65	47
5; 10; 20 Nm	81.5	70	50	40	44	55	4x5.50	30	55	65	47
50; 100; 200 Nm	72	55	35	50	50	64	4x6.60	30	64	73	55

## Accessory metal bellow coupling 8690



### Couplings

The compensation of misalignments is beside torque transmission the second essential function of a coupling. Generally, misalignments are classed in three categories:

	<b>Axial misalignment</b> This is change in length along the longitudinal axis of the drive shafts relative to each other.
	<b>Angular misalignment</b> This misalignment is caused by assembly related offsets of the drive shaft to the output shaft.
	<b>Lateral misalignment</b> This misalignment is a parallel offset of both shafts.

Misalignments interfere with the measurement and should be compensated largely.

### Metal bellow couplings for optimum compensation of misalignments

For optimum compensation of misalignments we recommend torsionally free metal bellow couplings. They are characterized by their excellent torsional stiffness during torque load and their low restoring forces. Whenever a rotational movement has to be transmitted, these couplings should be used.

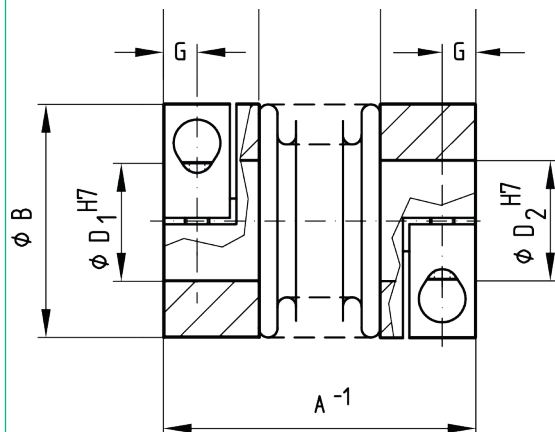

Rated torque [Nm]		0,5	1	2	10	30	60	150	200
Overall length [mm]	A	23	25	40	50	69	83	95	105
Outer diameter [mm]	B	15	15	25	40	55	66	81	90
Fit length to hub [mm]	C	6,5	6,5	13	16	27	31	36	41
Standard bore H7 [mm]	D1	8		15			26		
<b>Special bore H7 [mm]</b>	<b>D2</b>	<b>3-9</b>		<b>10-20</b>			<b>20-30</b>		
Screws ISO 4029	E	1xM3	1xM3	M3	M6	M6	M8	M10	M12
Tighting torque of assembly screw [Nm]	E3	1,3	1,3	2,3	4,5	15	40	70	120
Distance between centers [mm]	F			8	15	19	23	27	31
Distance [mm]	G	2	2	4	5	7,5	9,5	11	12,5

(for complete technical data: see data sheet 8690)

**Technical data**

**Electrical values**

Rated supply voltage range $U_s$ :	10 ... 30 V DC
Power consumption (without option):	approx. 2 W
Output voltage at $\pm$ rated torque:	$\pm$ 10 V
Output impedance:	1 k $\Omega$
Insulation resistance:	> 5 M $\Omega$
-3 dB cut-off frequency:	200 Hz
Ripple:	< 50 mV <sub>SS</sub>
Calibration signal:	10.00 V DC
Drive signal (pin K):	10 ... 30 V DC

**Supply and measurement channel are galvanically isolated.**

Power supply built-in connector:	hole diameter 5.7 mm center pin 2.0 mm
----------------------------------	---

**Speed/angular displacement measurement (option)**

Output without external circuit:	TTL level
Output with external circuit:	Open Collector
Internal pull-up resistor:	2 k $\Omega$ (5 V level)
External circuit (Open Collector output):	$U_{max} = 30 V / I_{max} = 30 mA$

Both pulse channels A and B are always available. Only one channel is needed for the speed measurement. Two channels are used for measuring the angular displacement (or detecting the direction of rotation).

Direction is detected by 2 pulse output channels; channel A leads channel B by 90° for clockwise rotation viewed from the drive end.

Angular displacement measurement:	
Resolution for encoder disk with 1,024 increments	0.09°
Resolution for encoder disk with 400 increments	0.225°

Speed measurement:	
max. rotational speed for an encoder disk with 400 increments	15,000 rpm
max. rotational speed for an encoder disk with 1,024 increments	6,000 rpm

(mechanical limit, see table 2: "Max. rotary speed")

**Environmental conditions**

Operating temperature range:	0 °C ... 60 °C
Rated temperature range:	0 °C ... 60 °C

Effect of temperature on the zero signal:	
range 1:1 (standard sensor)	$\pm$ 0.015% F.S./K
extendend range (dual range sensor)	+ 0.03 % F.S./K

Effect of temperature on the sensitivity:	
range 1:1 (standard sensor)	$\pm$ 0.01% F.S./K
extendend range (dual range sensor)	+ 0.02 % F.S./K

**Mechanical values**

Relative linearity deviation (standard sensor):	
Measuring range 0 ... 0.05 Nm	< $\pm$ 0.1 % F.S.
Measuring range 0 ... 0.1 to 0 ... 200 Nm	< $\pm$ 0.05 % F.S.
Relative linearity deviation (dual range sensor)	< $\pm$ 0.1 % F.S.
Relative reversal error (standard sensor):	
Measuring range 0 ... 0.05 Nm	< $\pm$ 0.1 % F.S.
Measuring range 0 ... 0.1 to 0 ... 200 Nm	< $\pm$ 0.05 % F.S.
Relative reversal error (dual range sensor):	< $\pm$ 0.1 % F.S.
Tolerance of the sensitivity (standard sensor):	$\pm$ 0.1 % F.S.
Tolerance of the sensitivity (dual range sensor):	$\pm$ 0.2 % F.S.
Max. operating torque (standard sensor):	200 % of rated torque
Max. operating torque (dual range sensor):	150 % of rated torque
Failure torque:	300 % of rated torque
Alternating load, referred to rated torque:	up to 70 %
Material:	housing made of anodized aluminum
Measurement range	
$\leq$ 0.2 Nm aluminum measuring shaft, shaft ends made of stainless steel 1.4542	
$\geq$ 0.5 Nm measuring shaft made of stainless steel 1.4542	
Degree of protection to EN 60529:	IP40
Weight:	see table 2/3
Electrical connection:	12-pin plug-in connection (type 9940 mating connector is supplied)
Fixing method: mounting holes are located on the end faces and the base; see table 1 and dimensional drawing	

**Mounting instructions**

When fitting the sensor, make sure that the measuring shaft is aligned as precisely as possible with the connecting shafts. Couplings must be employed to avoid strain on the sensor from parallel or angular displacement of the shafts. The permitted axial and radial forces (see table 2 and 3) must not be exceeded during fitting or operation. Please refer to our operating instructions for detailed information.

**Accessories**

12 pin mating connector (supplied with device)	<b>Model 9940</b>
12 pin mating connector, right-angle socket	<b>Model 9900-V539</b>
Connecting cable, (torque and rotational angle/speed), length 3 m, one end open	<b>Model 99540-000B-0270030</b>
Connecting cable, length 3 m, from torque sensor 8661 to DIGIFORCE® 9307 combined channel D (optional channel)	<b>Typ 99163-540A-0150030</b>
Connecting cable, length 3 m, from torque sensor 8661 without option angle/speed to 9163, desktop version.	<b>Typ 99209-540E-0160030</b>
Connecting cable, length 3 m, from torque sensor 8661 without option angle/speed to 9205-V3xxxx and 9310	<b>Typ 99209-540J-0090030</b>
Adapter cable to DIGIFORCE® 9307 standard channel A/B and C (usable only in connection with type 99163-540A-015xxxx)	<b>Typ 99209-215A-0090004</b>
Power pack for external supply	<b>Model 8600-Z010</b>
Mounting block (see dimensional drawing on page 5)	
measurement range 0 ... $\pm$ 0.05 Nm up to 0 ... 2 Nm	<b>Model 8661-Z001</b>
measurement range 0 ... $\pm$ 5 Nm up to 0 ... $\pm$ 20 Nm	<b>Model 8661-Z002</b>
measurement range 0 ... $\pm$ 50 Nm up to 0 ... 200 Nm	<b>Model 8661-Z003</b>
Couplings	<b>Series 8690</b>
<b>Display and evaluation instruments</b>	
Torque	e.g. <b>SENSORMASTER Model 9163</b>
Torque and angle	e.g. <b>DIGIFORCE® Model 9307</b> see section 9 of the catalog

**Order Code**

<b>Torque sensor</b>	<b>model 8661-5XXX-V</b>	<input type="checkbox"/>	<input type="checkbox"/>	<input type="checkbox"/>	<input type="checkbox"/>
Standard sensor	0				
Sensor with dual ranges 1:10	1				
Sensor with dual ranges 1:5	2				
Sensor with dual ranges 1:4	3				
Without angle/speed meas.	0				
Angle measurement resolution 0.225°/ Speed measurement	1				
Angle measurement resolution 0.09°/ Speed measurement	2				
Output voltage 0 ... 10 V	0				
USB interface	1				
Round shaft ends	0				
Shafts ends with keyway (Keyway to DIN 6885, Bl. 1)	2				

**Order Information**

Torque sensor, measurement range  $\pm$  20 Nm, with high-resolution angle measurement 0.09° **Model 8661-5020-V0200**  
 Precision torque sensor, measurement range 100 Nm, rotating, with high resolution angle measurement 0,09°, with option 2 ranges, range extension 1:5  
 1. range:0 ...100 Nm; 2. range: 0 ... 20 Nm  
 with USB interface incl. measurement- and evaluation software  
**8661-P001 Typ 8661-5100-V2210**

**Manufacturer Calibration Certificate (WKS)**

Calibration of a sensor or a sensor with display instruments, clockwise and/or counterclockwise torque in 20 % steps, increasing and decreasing.