

Infrared Cameras

The most portable
infrared online camera

- Temperature measurement -20°C to 900°C
- Small cameras - Ideal for OEM applications
- 120 Hz for fast processes
- Including software package and open drivers

NEW: With BI-SPECTRAL technology





Automatic hot spot detection

Objects can be examined thermally and **hot or cold positions** (hot or cold spots) can be found automatically.

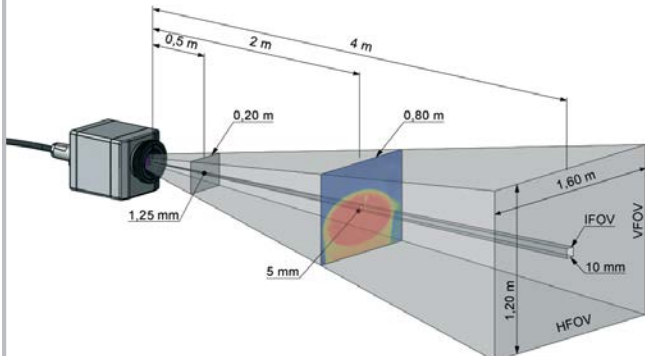

Measurement field of the thermal imager Optris PI as an example with the standard lens 23° x 17°



Fast measurements

Temperature distributions at surfaces can be captured precisely within an **millisecond interval**.

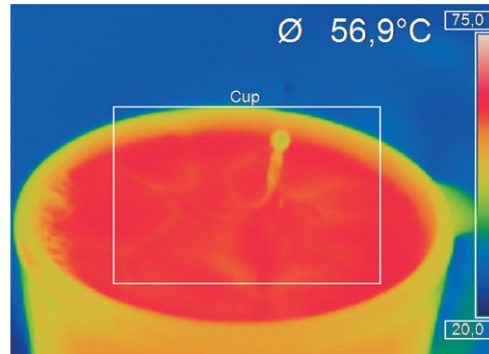

A milk drop falls into a coffee cup



Portable and stationary

The cameras fill the existing gap between **portable** infrared snap shot cameras and pure **stationary** devices. Possible applications are for example:

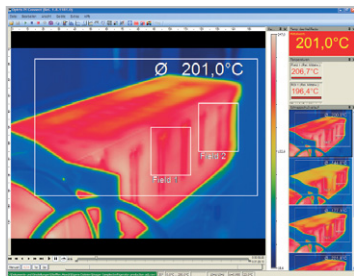

Process automation

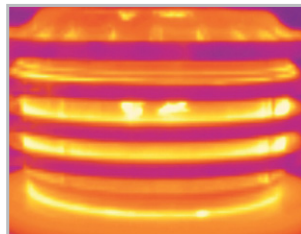

Test stations

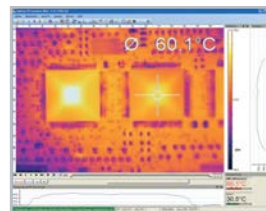

Research & Development



Portable measurement tasks



Easy process integration

Advanced interface concepts allow the integration within networks and automated systems:

- USB cable extension up to 100 m (over Ethernet) or 10 km (over fibre)

- Process interface (PIF) at the camera as analog input / output (0 to 10 V) and digital input (low- and high-level)
- Software interface via Dynamic-link Library (DLL), Computer-Port (ComPort) and LabVIEW



optris® PI160
Thermal imager with 120 Hz frame rate



Important Features

- Outstanding price-performance ratio
- Detector with 160 x 120 pixel
- Thermal images in real time with 120 Hz
- Very good thermal sensitivity starting from 0.08K
- Small design (Size: 45 x 45 x 62 mm³)
- Thermo Analysis Kit incl. 3 lenses (optional)

Small camera - Ideal for OEM applications

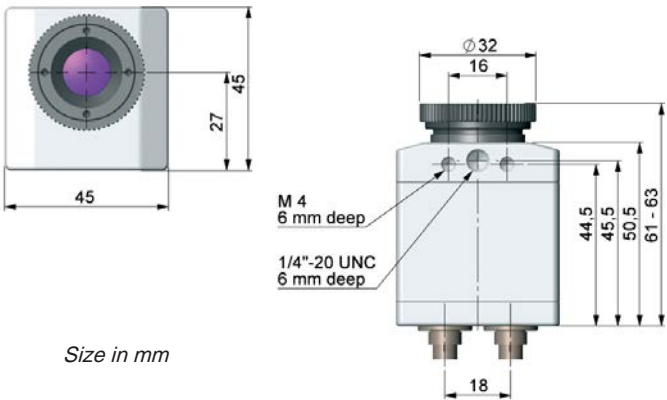

Industrial Accessory

The infrared cameras are available with a housing with **protection class IP 67 (NEMA-4)**. The use of the device takes place at the following temperatures...

- ... up to **50°C** without cooling housing
- ... up to **100°C** with cooling housing (air cooling)
- ... up to **240°C** with cooling housing (water cooling)



Additional industrial accessory is available, such as the **USB high temperature cable** up to 20 m.

Cooling housing with air and water cooling option

Fitting lenses for each distance

Accurate measurement field sizes can be calculated online www.optris.com/optics-calculator.

Lens	Focal Length	Minimum Distance	Object distance [m]												
				0.02	0.1	0.2	0.3	0.5	1.2	2	4	6	10	30	100
23° x 17° Standard lens	10 mm	0.02 m*	HFOV [m]	0.008	0.04	0.08	0.12	0.20	0.48	0.80	1.60	2.4	4.0	12.0	40.0
			VFOV [m]	0.006	0.03	0.06	0.09	0.15	0.36	0.60	1.20	1.8	3.0	9.0	30.0
			IFOV [mm]	0.050	0.25	0.50	0.75	1.25	3.00	5.00	10.00	15.0	25.0	75.0	250.0
6° x 5° Tele lens	35.5 mm	0.5 m	HFOV [m]					0.06	0.14	0.23	0.45	0.7	1.1	3.4	11.3
			VFOV [m]					0.04	0.10	0.17	0.34	0.5	0.8	2.5	8.5
			IFOV [mm]					0.35	0.85	1.41	2.82	4.2	7.0	21.1	70.4
48° x 37° Wide angle lens	4.5 mm	0.02 m*	HFOV [m]	0.018	0.09	0.18	0.27	0.44	1.07	1.78	3.56	5.3	8.9	26.7	88.9
			VFOV [m]	0.013	0.07	0.13	0.20	0.33	0.80	1.33	2.67	4.0	6.7	20.0	66.7
			IFOV [mm]	0.111	0.56	1.11	1.67	2.78	6.67	11.11	22.22	33.3	55.6	166.7	555.6

*Note: The accuracy of measurement can be outside the specifications for distances below 0.2 m.



optris® PI200
Thermal imager with BI-SPECTRAL technology



Important Features

- **NEW:** BI-SPECTRAL technology
- Thermal images in real time with 96 Hz (160 x 120 pixel)
- Time synchronic visual image recording with 32 Hz (640 x 480 pixel)
- Low-light-level technology of visual camera
- Small design (Size: 45 x 45 x 62 mm³)
- Thermo Analysis Package incl. 3 lenses (optional)

Small camera - Ideal for OEM applications

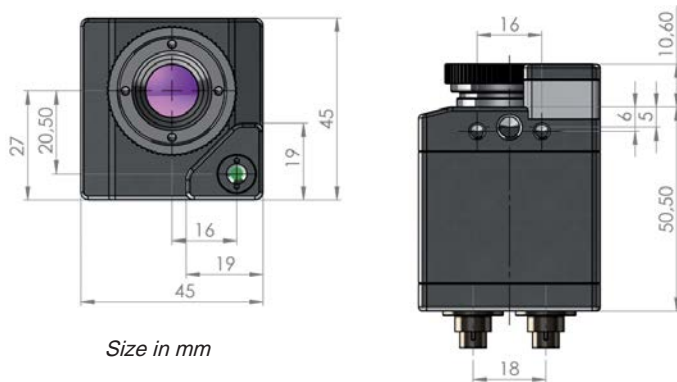

BI-SPECTRAL technology

With the help of BI-SPECTRAL technology, a **visual image** (VIS) can be combined with a **thermal image** (IR). Both can be finally captured time synchronously:

Monitoring modus:

Easy orientation at point of measurement

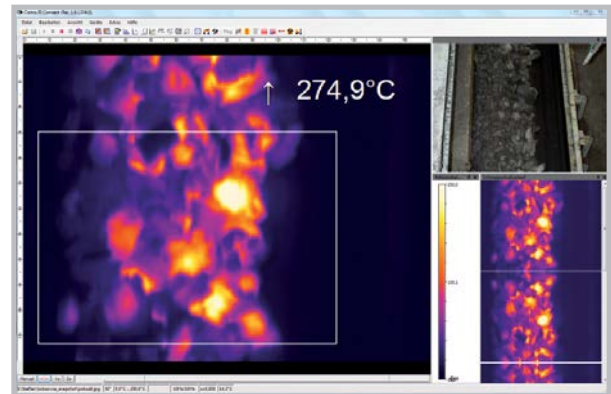

Fitting lenses for each distance

Hand as device under test

Measuring field size: 240 mm x 180 mm, pixel size: 1.5 mm

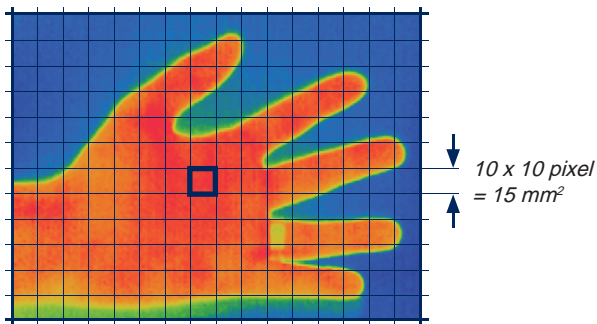

Same measurement field size using different lenses:

- Standard lens: 0.6 m measuring distance
- Tele lens: 2.13 m measuring distance
- Wide angle lens: 0.27 m measuring distance

Calculation of accurate measurement fields at our website www.optris.com/optics-calculator.

Cross-fading modus:

Highlighting of critical temperatures

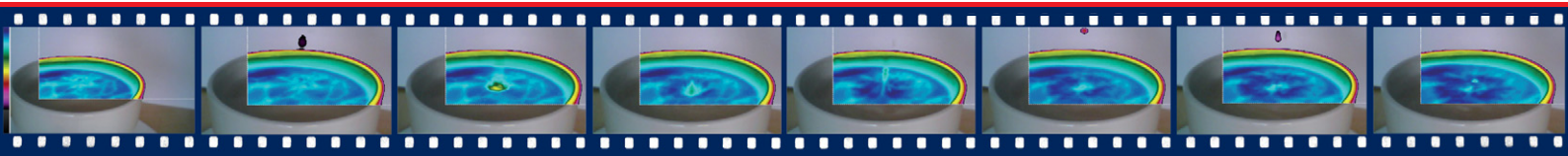
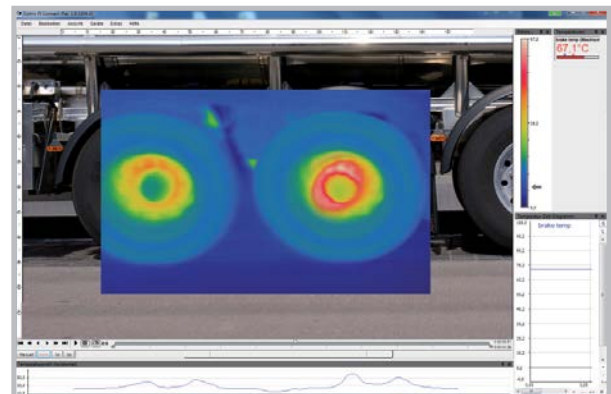

Technical data of the infrared cameras

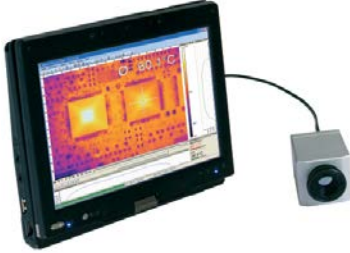
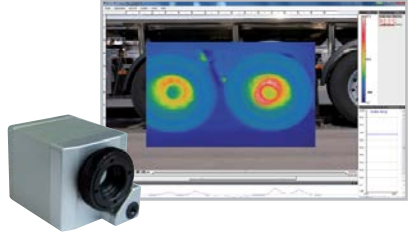
Basis model	PI160	PI200
Type	IR	BI-SPECTRAL
		
Classification	USB camera incl. 1 lens, USB cable (1 m), table tripod, PIF cable incl. terminal block (1 m), software package optris PI Connect, aluminium case	USB camera with 1 lens and BI-SPECTRAL technology, USB cable (1 m), table tripod, PIF cable incl. terminal block (1 m), software package optris PI Connect, aluminium case
Detector	FPA, uncooled (25 µm x 25 µm)	FPA, uncooled (25 µm x 25 µm)
Optical resolution	160 x 120 pixel	160 x 120 pixel
Spectral range	7,5 - 13 µm	7,5 - 13 µm
Temperature ranges	-20°C...100°C, 0°C...250°C, 150°C...900°C	-20°C...100°C, 0°C...250°C, 150°C...900°C
Frame rate	120 Hz	96 Hz
Optics (FOV)	23° x 17° FOV / f = 10 mm <u>or</u> 6° x 5° FOV / f = 35,5 mm <u>or</u> 48° x 37° FOV / f = 4,5 mm	23° x 17° FOV / f = 10 mm <u>or</u> 6° x 5° FOV / f = 35,5 mm <u>or</u> 48° x 37° FOV / f = 4,5 mm
Thermal sensitivity (NETD)	0.08 K with 23° x 17° FOV / F = 0,7 0.3 K with 6° x 5° FOV / F = 1,6 0.1 K with 48° x 37° FOV / F = 1	0.08 K with 23° x 17° FOV / F = 0,7 0.3 K with 6° x 5° FOV / F = 1,6 0.1 K with 48° x 37° FOV / F = 1
Option for visual camera (only for BI-SPECTRAL camera)		Optical resolution: 640 x 480 Pixel Frame rate: 32 Hz Optics (FOV): 54° x 40°
Accuracy	±2°C or ±2%	±2°C or ±2%
PC interface	USB 2.0	USB 2.0
Process interface (PIF)	0 - 10 V input, digital input, 0 - 10 V output	0 - 10 V input, digital input, 0 - 10 V output
Ambient temperature (T _{Umw})	0°C...50°C	0°C...50°C
Storage temperature	-40°C...70°C	-40°C...70°C
Relative humidity	20 - 80%, non condensing	20 - 80%, non condensing
Enclosure (size / rating)	45 mm x 45 mm x 62 mm / IP 67	45 mm x 45 mm x 62 mm / IP 67
Weight	195 g, incl. lens	215 g, incl. lens
Shock / vibration	25G, IEC 68-2-29 / 2G, IEC 68-2-6	25G, IEC 68-2-29 / 2G, IEC 68-2-6
Tripod mount	1/4-20 UNC	1/4-20 UNC
Power supply	USB powered	USB powered

The optris PI thermal imager as Thermal Analysis Package

- Infrared camera optris PI160 or PI200
- 3 lenses including calibration certificate
- USB cable (1 m and 10 m)
- Table tripod (20 - 63 cm)
- PIF cable with terminal block (1 m)
- Software package optris PI Connect
- Aluminum case

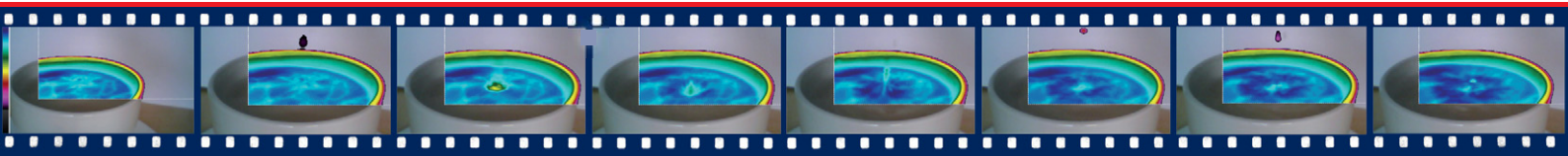
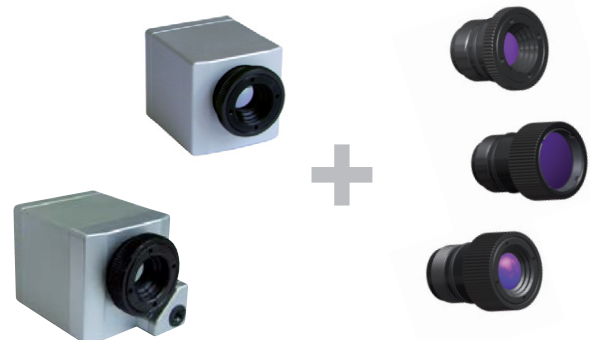



Extensive infrared camera software

- No additional costs
- No restrictions in licencing
- Modern software with intuitive user interface
- Remote control of camera via software
- Display of multiple camera images in different windows
- Compatible with Windows XP, Vista and 7 as well as LabVIEW*

1.

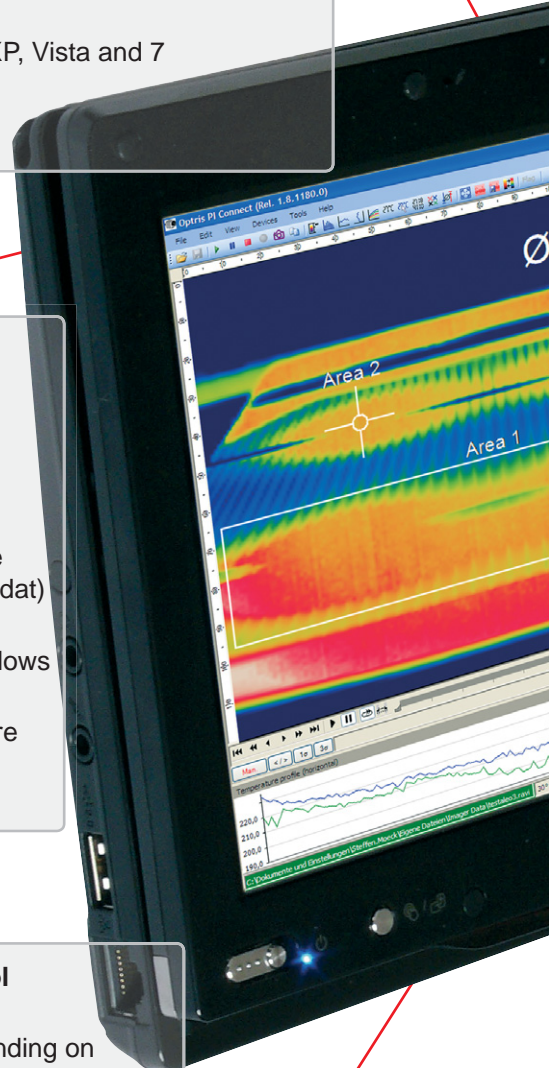

6.

Temperature data analysis and documentation

- Triggered data collection
- Radiometric video sequences (*.ravi)
- Radiometric snapshots (*.jpg, *.tiff)
- Text files including complete temperature information for analysis in Excel (*.csv, *.dat)
- Data with color information for standard programmes such as Photoshop or Windows Media Player (*.avi, *.jpg, *.tiff)
- Data transfer in real time to other software programmes via LabVIEW-, DLL- or Comport interfaces

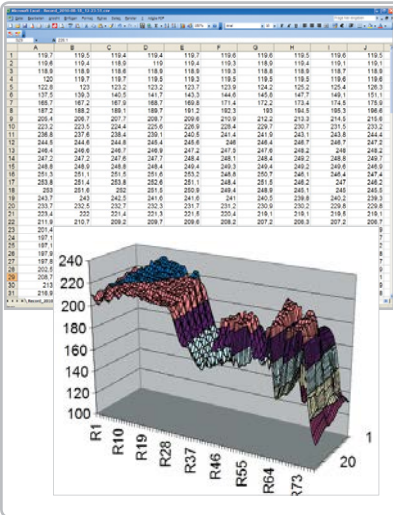

Automatic process and quality control

- Individual setup of alarm levels depending on the process
- BI-SPECTRAL monitoring modus (IR and VIS) for easy orientation at the measuring point
- Linescanner function for process monitoring at moving objects
- Definition of visual or acoustic alarms and analog data output
- Analog and digital signal input
- External communication of software via Comports, DLL and LabVIEW driver
- Adjustment of thermal image via reference values

5.

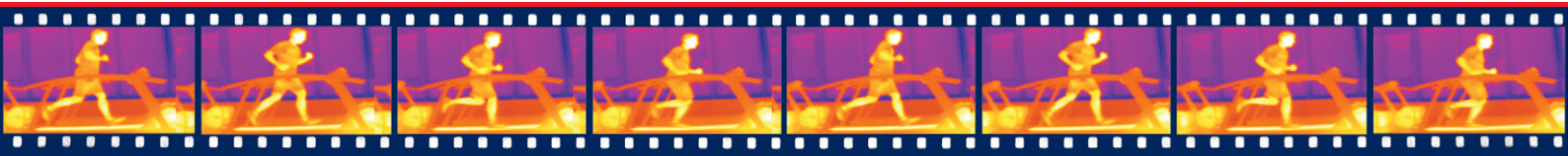
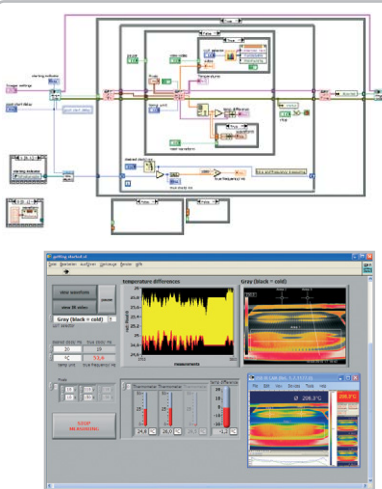

2. High level of individualization for customer specific display

- Different layout options for an individual setup (arrangement of windows, toolbar)
- Temperature display in °C or °F
- Various language options including a translation tool
- Range of individual measurement parameter fitting for each application
- Adaption of thermal imager (mirror, rotate)
- Individual start options (full screen, hide, etc.)

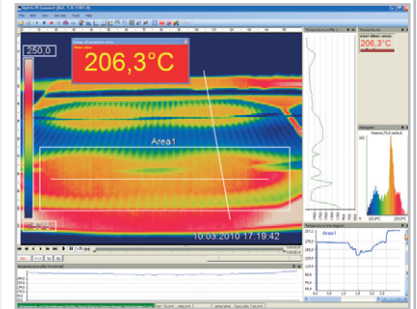

3. Video recording and snapshot function (IR or BI-SPECTRAL)

- Recording of video sequences and detailed frames for further analysis or documentation
- BI-SPECTRAL video analysis (IR and VIS) to highlight critical temperatures
- Adjustment of recording frequency to reduce data volume
- Display of snapshot history for immediate analysis

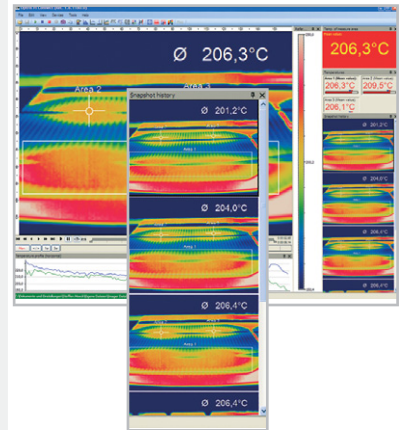

4. Extensive online and offline data analysis

- Analysis supported by measurement fields, hot and cold spot searching, image subtraction
- Real time temperature information within main window as digital or graphic display (line profile, temperature time diagram)
- Slow motion repeat of radiometric files and analysis without camera being connected
- Editing of sequences such as cutting and saving of individual images
- Various color palettes to highlight thermal contrasts

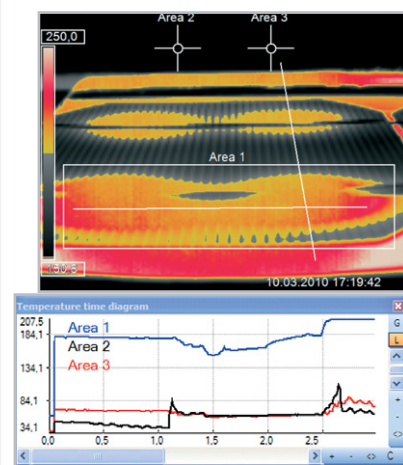

*Windows is a registered trademark of Microsoft Corporation. LabVIEW is a registered trademark of National Instruments.

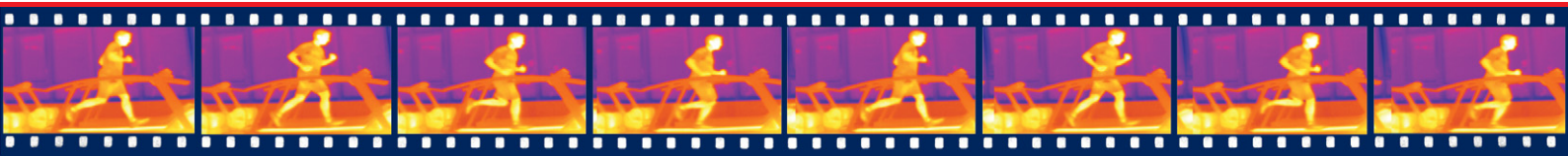



MTS **Messtechnik Schaffhausen GmbH**
Mühlenstrasse 4, CH-8260 Stein am Rhein
Telefon +41 52-672 50 00
Telefax +41 52-672 50 01
www.mts.ch, e-mail: info@mts.ch

Messen Prüfen Automatisieren www.mts.ch

